

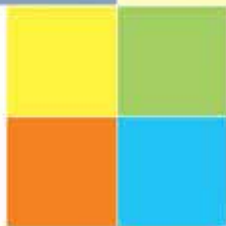

K A N C E L Á R E

profil®
NÁBYTEK



S
E
R
E
S
P
R
O
G
R
E
S
I
V
N
Í

F U N K Č N Í

P O K R O K O V Ý

P R O G R E S I V N Í

M
L
E
M
S
R
I
T
E
R
I
N



P R O G R E S

5





P R O G R E S





P R O G R E S



PROGRES

JE VARIABILNÍ KANCELÁŘSKÝ
A KONFERENČNÍ SYSTÉM,
Z KTERÉHO SE DAJÍ SNADNO
SESTAVIT LIBOVOLNÁ
A PŘESTAVITELNÁ PRÁCOVIŠTĚ VŠECH KATEGORIÍ.
MALÝCH I VELKOPLOŠNÝCH KANCELÁŘSKÝCH INTERIÉRŮ
S RŮZNÝM STUPNĚM VYBAVENOSTI.



K A N C E L Á Ř E

profil[®]
NÁBYTEK

P
R
O
G
R
E
S
I
V
N
Í

F
U
N
K
Č
N
Í

P
O
K
R
O
K
O
V
Ý

P
R
O
G
R
E
S
I
V
N
Í

M
E
L
I
F
O
R
P
S
R
É
I
N
T
E
R
I
E
R
N
Í

"PROGRES"

FUNCTIONAL, ADVANCED, RELIABLE

THIS INNOVATIVE OFFICE FURNITURE WAS DEVELOPED IN ACCORDANCE WITH FOLLOWING INCREASED DEMANDS

- IT MUST CREATE A COMFORTABLE WORKING ENVIRONMENT AND COMPLY WITH OPTIMAL ERGONOMICS
- IT MUST REPRESENT A COMPACT SYSTEM
- IT MUST BE A SET OF SPACE-SAVING MODULES WITH THE POSSIBILITY OF CHANGES/COMPLETION
- IT MUST HAVE SUFFICIENT VARIABLE STOWAGE SPACE
- IT MUST PROVIDE AN ALTERNATIVE SOLUTION
- IT MUST BE CHARACTERIZED BY AN EXCELLENT WORKMANSHIP
- IT MUST POSSES HIGH-QUALITY AND LONG DURABILITY
- IT MUST ACHIEVE THE OPTIMAL BALANCE BETWEEN PRICE AND QUALITY
- IT MUST COMPLY WITH THE CRITERIA OF "ECOLOGICALLY FRIENDLY PRODUCT"

PROGRES IS VARIABLE OFFICE AND CONFERENCE SYSTEM FROM WHICH CAN BE EASILY COMPLETED ANY ADJUSTABLE WORKPLACE OF ALL CATEGORIES IN SMALL AND/OR LARGE OFFICE INTERIORS WITH VARIOUS DEGREE OF EQUIPMENT

TREATMENT INSTRUCTIONS FOR THE FURNITURE

- DO NOT MOVE A HEAVY OBJECTS WITH SHARP EDGES & ROUGH SURFACE ALONG THE FURNITURE
- AVOID STRONG IMPACT OF HARD OBJECTS INTO THE SURFACES AND EDGES
- DON'T PLACE ANY OBJECTS WITHOUT USING SOFT AND CLEAN UNDERLAY (QUILT, CORRUGATED CARDBOARD) ON THE FURNITURE'S SURFACE WHEN MOVING AND HANDLING IT
- DON'T USE ANY KIND OF POLISH FOR THIS FURNITURE
- IF THERE HAPPENS MAJOR MECHANICAL DAMAGE OF THE FURNITURE YOU NEED TO ASK FOR THE EXPERT'S HELP
- RESISTS TO RAISED TEMPERATURE, FATS, CHEMICALS AND ORGANIC SOLVENTS. TEPID WATER WITH THE ADDITION OF ANY NORMAL DETERGENT CAN BE USED FOR WASHING OF A GENERAL DIRT

IF YOU COMPLY WITH THESE INSTRUCTIONS, OUR PRODUCT WILL SERVE TO YOUR FULL SATISFACTION.

ECOLOGY: HYGIENIC AND HEALTH UNEXCEPTIONABILITY OF THE OFFICE FURNITURE

"**PROGRES**" IT'S GUARANTEED BY THE MARK OF „ENVIRONMENTALLY FRIENDLY PRODUCT". THE FURNITURE RECEIVED THIS MARK AFTER SERIES OF EXAMS AND TESTS. APPLIED MATERIALS ARE ECOLOGICALLY RECYCLABLE AND PRODUCTION OF THE FURNITURE DOESN'T LOAD THE ENVIRONMENT.

THE COMPANY „**PROFIL NÁBYTEK**" IS READY TO PROVIDE YOU PROFESSIONAL SERVICES FROM AN ADVISEMENT, A 3D DRAWING UP OF THE ARCHITECTONIC DESIGN TO A TRANSPORT AND ASSEMBLY OF THE FURNITURE. WE PROVIDE THE GUARANTEE OF 5 YEARS FOR THIS FURNITURE.

DELIVERY TERMS:

STANDARD DELIVERY TERM IS MAX. 4 WEEKS.

CABINET SYSTEM

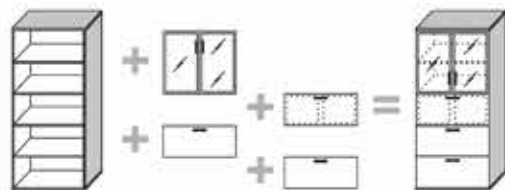
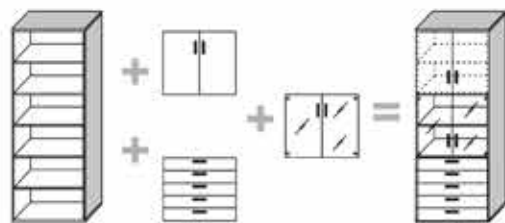
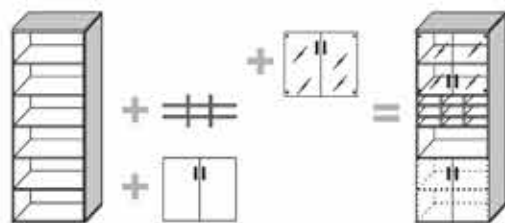

THE WARDROBES ARE MADE SO THAT THE BOTTOM AND THE TOP ARE MADE OUT OF LAMINATED PARTICLE BOARD 25 MM THICK. THE SIDE WALLS, THE FULL DOORS AND THE SHELVES ARE MADE OUT OF LAMINATED PARTICLE BOARD 18 MM THICK. THE BACK IS MADE OUT OF TWO-SIDE-LAMINATED PARTICLE BOARDS 8 MM THICK, BEDDING INTO SLOTS. THE CASES AND VARIABLE SHELVES ARE EDGED WITH 2 MM ABS TAPE ON THE FRONT SIDE. FROM THE REAR, THEY ARE EDGED WITH ABS TAPE 0.5 MM THICK. THUS, ANY WARDROBE CAN STAND IN THE ROOM'S SPACE AND/OR YOU CAN CREATE DIVISION WALLS WITH THE CABINETS. FULL DOORS AND DRAWERS ARE EDGED WITH 2 MM ABS TAPE AS WELL. SELF-CLOSING DOORS ARE LOADED ON THE HINGES FROM BLUM COMPANY. EITHER THE METABOX DRAWER SYSTEM (HALF-DRAWING AND FULL-DRAWING) IS FROM BLUM COMPANY. WE PROVIDE LIFETIME GUARANTEE ON THIS HARDWARE. DOOR LOCKING CAN BE ORDERED AS A SPECIAL FEATURE. THE HANDLES ARE USED IN HIGHER QUALITY THAN REQUIRED AND THEY ARE IN THE COLOUR OF ALUMINIUM - ACCORDING TO YOUR CHOICE.

CABINETS CAN ALSO BE ORDERED IN CHEAPER VERSION „PROGRES EKO“. THE CHANGE IS THAT THERE IS USED BACK 3.3 MM THICK. THE CABINETS ARE NOT EDGED FROM BEHIND. FRONT EDGES OF THE SIDE PANELS AND OF THE SHELVES ARE EDGED WITH ABS TAPE 0.5 MM THICK. BOTTOM AND TOP REMAINS EDGED WITH ABS TAPE 2 MM THICK AS WELL AS CIRCUMFERENCE OF THE DOORS AND DRAWERS. THERE ARE USED CHEAPER HOLDS AND HINGES FROM THE FIRM FGV.

INDIVIDUAL CABINET MODULES ARE SHIPPED FULLY ASSEMBLED AND GLUED. THIS ENSURES BETTER TOUGHNESS OF THE FURNITURE.

THE CABINET SYSTEM IS SUITABLE FOR CREATION OF PRACTICAL STORAGE SHELF OR CABINET SETS FOR A FILES, HANGING REGISTERS, OFFICE SUPPLIES OR EVEN CLOTHES.

THERE CAN BE HANGED FIVE HEIGHT MODULES OF FULL DOORS, GLASS DOORS AND GLASS DOORS IN ALUMINIUM FRAME INTO FIVE HEIGHT OPTIONS (750, 1095, 1440, 1795, 2130 MM) AND THREE WIDTH (900, 600, 400 MM) MODULES SOEVER. UNITARY DEPTH OF THE CASES IS 402 MM. THERE CAN BE USED SLAT DOORS (SILVER OR BLACK), HANGING REGISTERS AND DRAWERS AT THE LOWER MODULES. A PLETHORA VARIANTS OF VARIOUS SETS CAN BE CREATED IN THIS WAY. LOW HEIGHT-ADJUSTABLE FEET CONTROLLABLE FROM THE INSIDE OF THE CASES MAKE THE SETTING OF THE FURNITURE IN A HORIZONTAL POSITION MUCH EASIER AS THEY HELP TO OFFSET ANY UNEVEN FLOORS. MEDIAL SHELF NICHES CAN BE THICKENED WITH A SHELF INSERTS. WE HAVE PREPARED A SERIES OF TYPIFIED WARDROBE MODULES IN ALL HEIGHT AND WARDROBE SIZES INTO BASIC OFFER.

CASE HEIGHT 213 CM



X-100
80 x 40 x 213
S1 N

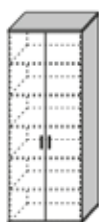

X-101
80 x 40 x 213
S1 DP

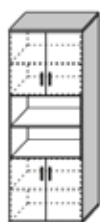

X-102
80 x 40 x 213
S1 DND

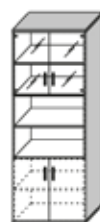

X-103
80 x 40 x 213
S1 SND

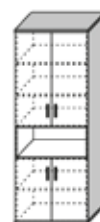

X-104
80 x 40 x 213
S1 DND

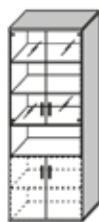

X-105
80 x 40 x 213
S1 SND

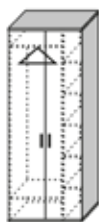

X-106
80 x 40 x 213
S1 SAT.

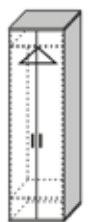

X-120
60 x 40 x 213
S1 SAT.

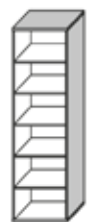

X-121
60 x 40 x 213
S1 N

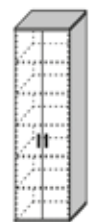

X-122
60 x 40 x 213
S1 DP



X-140
40 x 40 x 213
S1 N



X-141
40 x 40 x 213
S1 DP



X-150
40 x 40 x 213
S1 RK

CASE HEIGHT 178,5 CM



X-160
80 x 40 x 178,5
S2 N

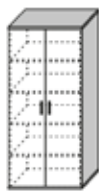

X-161
80 x 40 x 178,5
S2 DP

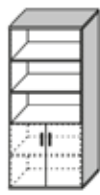

X-162
80 x 40 x 178,5
S2 ND

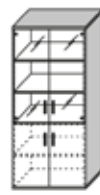

X-163
80 x 40 x 178,5
S2 SD

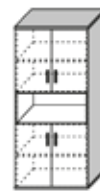

X-164
80 x 40 x 178,5
S2 DND

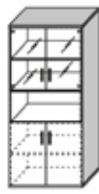

X-165
80 x 40 x 178,5
S2 SND

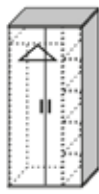

X-166
80 x 40 x 178,5
S2 SAT.

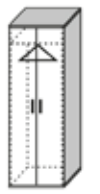

X-180
60 x 40 x 178,5
S2 SAT.



X-181
60 x 40 x 178,5
S2 N

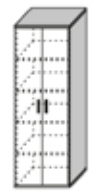

X-182
60 x 40 x 178,5
S2 DP



X-200
40 x 40 x 178,5
S2 N

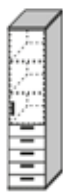

X-201
40 x 40 x 178,5
S2 DZ



X-210
40 x 40 x 178,5
S2 RK

STANDARD CABINET SETS
(FOR SPECIAL PRICE)

CASE HEIGHT 144 CM

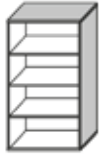

X-220
80 x 40 x 144
S3 N

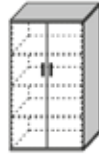

X-221
80 x 40 x 144
S3 DP

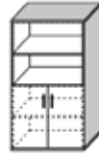

X-222
80 x 40 x 144
S3 ND

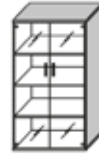

X-223
80 x 40 x 144
S3 S

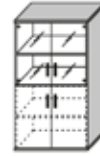

X-224
80 x 40 x 144
S3 SD



X-225
80 x 40 x 144
S3 SR

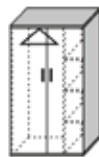

X-226
80 x 40 x 144
S3 SAT.

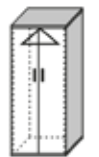

X-240
80 x 40 x 144
S3 SAT.

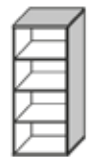

X-241
80 x 40 x 144
S3 N

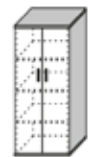

X-242
80 x 40 x 144
S3 DP

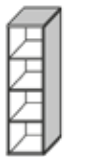

X-260
40 x 40 x 144
S3 N

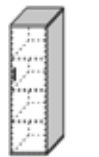

X-261
40 x 40 x 144
S3 DP

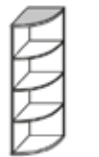

X-270
40 x 40 x 144
S3 RK

CASE HEIGHT 109,5 CM



X-280
80 x 40 x 109,5
S4 N

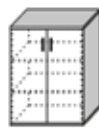

X-281
80 x 40 x 109,5
S4 DP



X-282
80 x 40 x 109,5
S4 ND



X-283
80 x 40 x 109,5
S4 S



X-284
80 x 40 x 109,5
S4 SR



X-285
80 x 40 x 109,5
S4 3Z 6ZK



X-286
80 x 40 x 109,5
S4 ROL



X-300
80 x 40 x 109,5
S4 N

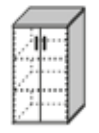

X-301
80 x 40 x 109,5
S4 DP



X-310
40 x 40 x 109,5
S4 N

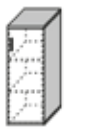

X-311
40 x 40 x 109,5
S4 DP

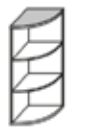

X-320
40 x 40 x 109,5
S4 RK

STANDARD CABINET SETS
(FOR SPECIAL PRICE)

CASE HEIGHT 75 CM



X-330
80 x 40 x 75
S5 N



X-331
80 x 40 x 75
S5 DP



X-332
80 x 40 x 75
S5 S



X-333
80 x 40 x 75
S5 SR



X-334
80 x 40 x 75
S5 2Z 4ZK



X-335
80 x 40 x 75
S5 R0L



X-350
60 x 40 x 75
S5 N



X-351
60 x 40 x 75
S5 DP



X-360
40 x 40 x 75
S5 N



X-361
40 x 40 x 75
S5 DP



X-362
40 x 40 x 75
S5 Z5



X-370
40 x 40 x 75
S5 RK

CASTOR
CONTAINERS



X-380
49 x 46 x 60
K6 KONT.PC



X-381
122 x 46 x 60
K6 KONT.3Z 2ZK



X-382
122 x 46 x 60
S6 KONT.4Z 1ZK



X-400
42 x 61 x 60
KZ KONT.3Z



X-401
42 x 61 x 60
KZ KONT.3Z 1T



X-402
42 x 61 x 60
KZ KONT.1Z 1ZK

TABLE
(FILE) CABINETS



X-405
42 x 80 x 75
KZ KP 2ZK



X-406
42 x 80 x 75
KZ KP 2Z 1ZK 1T



X-407
42 x 80 x 75
KZ KP 4Z 1T



X-410
42 x 61 x 75
KZ KP 2ZK



X-411
42 x 61 x 75
KZ KP 2Z 1ZK 1T



X-412
42 x 61 x 75
KZ KP 4Z 1T

TECHN. DESCR. OF CONTAINERS

THE FIXED & CASTOR CONTAINERS HAVE BOTTOM & TOP PRODUCED OUT OF LAMINATED PARTICLE BOARD 25 MM THICK, JUST LIKE THE CABINET FURNITURE. THE SIDE WALLS AND THE FACE AND BACK OF THE DRAWERS ARE MADE OUT OF LAMINATED PARTICLE BOARD 18 MM THICK. EVERYTHING IS ALL AROUND EDGED WITH ABS TAPE 2 MM THICK. HALF-DRAWING AND FULL-DRAWING METABOX TYPE DRAWER AND FILLING SYSTEMS ARE SUPPLIED BY BLUM COMPANY AND THESE HAVE LIFETIME GUARANTEE. SOME TYPES OF CONTAINERS ARE EQUIPPED WITH PEN RACKS AND WITH DRAWERS FOR HANGING REGISTERS WITH 100% EXTENSION. ALL FILLING SYSTEMS WORK EASY AND QUIET. THE DRAWING CONTAINERS ARE FITTED WITH CENTRAL LOCKING BY DEFAULT. THE CONTAINER PROGRES EKO DIFFERS ONLY BY THE USED HANDLES WHICH CORRESPONDS WITH THE EKO WARDROBE LINE. THE REST OF THE CONTAINER IS IDENTICAL.

CONTAINERS ARE SHIPPED FULLY ASSEMBLED AND GLUED.

SINGLE SHELVES
ON THE WALL



1-840
.. x 20 x 2,5
SHELF (BM)



1-841

SHELF FIXTURE „TUKAN“

YOU CAN FIND IN THE PRICE LIST INDEPENDENTLY STILL:

LOCKS FOR THE CABINETS
2-990 2-991 2-992 2-993 2-994 2-995

AND

REPLACEMENT SHELVES TO THE CASES
X-970 X-971 X-972 X-973



X-842
80 x 32 x 37,7
SHELF



X-843
120 x 32 x 37,7
SHELF



X-844
140 x 32 x 37,7
SHELF



X-845
160 x 32 x 37,7
SHELF

**COMPONENTS
FOR VARIANT FURNITURE SETS
AT CASE WIDTH 800 MM**

CASES

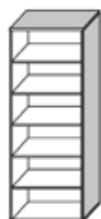

X-100
80 x 40 x 213
S1 N



X-160
80 x 40 x 178,5
S2 N



X-220
80 x 40 x 144
S3 N



X-280
80 x 40 x 109,5
S4 N



X-330
80 x 40 x 75
S5 N

FULL DOORS



X-900
80 x 206,6
FULL DOOR



X-901
80 x 172,1
FULL DOOR



X-902
80 x 137,6
FULL DOOR



X-903
80 x 103,1
FULL DOOR



X-904
80 x 68,6
FULL DOOR

GLASS DOORS



X-905
80 x 206,6
GLASS DOOR



X-906
80 x 172,1
GLASS DOOR



X-907
80 x 137,6
GLASS DOOR



X-908
80 x 103,1
GLASS DOOR



X-909
80 x 68,6
GLASS DOOR

GLASS DOORS
IN ALUMINIUM FRAME



X-910
80 x 206,6
GLASS D.+AL FRAME



X-911
80 x 172,1
GLASS D.+AL FRAME



X-912
80 x 137,6
GLASS D.+AL FRAME

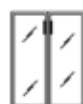

X-913
80 x 103,1
GLASS D.+AL FRAME



X-914
80 x 68,6
GL.D.+AL FRAME

SLAT
DOORS

SLAT DOORS
WE PRODUCE SLAT DOORS ONLY IN THESE THREE HEIGHTS. THEY CAN BE USED WITH THE CABINETS OF THE SAME HEIGHT ONLY. THEREFORE, THEY CAN'T BE COMBINED WITH OTHER COMPONENTS.



X-915
76 x 138
SLAT DOOR



X-916
76 x 103
SLAT DOOR



X-917
76 x 70
SLAT DOOR

DRAWERS AND
FILLING CABINETS

DRAWING AND FILLING CABINET MODULES CAN BE USED IN THE FOUR LOWER SHELVES IN THE CABINET. HIGHER POSITIONS ARE POORLY ACCESSIBLE. THESE ARE INDEPENDENT DRAWING SYSTEMS METABOX WHICH NEED TO BE FORGED INTO CABINETS.

FILLING CABINET
MODULE (2)
IN ONE DRAWER
INTO ONE SHELF



X-918
79,6 x 34,5
FILLING CABINET

SINGLE-DRAWING
MODULE
INTO ONE SHELF



X-919
79,6 x 34,5
SINGLE-DRAWER

TWO-DRAWING
MODULE
INTO ONE SHELF



X-920
79,6 x 34,5
TWO-DRAWER

FIVE-DRAWING
MODULE
INTO TWO SHELVES



X-921
79,6 x 68,5
FIVE-DRAWER

DIVIDING
SHELF
INSERTS

DIVIDING SHELF INSERTS
DIVIDING INSERTS CAN NEVER BE INSERTED INTO THE VERY BOTTOM OR THE VERY TOP SHELF OF THE CABINET. THICKENING INSERTS ARE USED TO CREATE SHELF FILLING CABINET. DIMENSIONS CORRESPOND TO A4 SIZE PAPERS.



X-974
76,4 x 35,8 x 32,7
DIVIDING SHELF



X-975
76,4 x 35,8 x 32,7
DIVIDING SHELF

CASES



X-121
60 x 40 x 213
S1 N



X-181
60 x 40 x 178,5
S2 N



X-241
60 x 40 x 144
S3 N



X-300
60 x 40 x 109,5
S4 N



X-350
60 x 40 x 75
S5 N

FULL DOORS



X-925
60 x 206,6
FULL DOOR



X-926
60 x 172,1
FULL DOOR



X-927
60 x 137,6
FULL DOOR



X-928
60 x 103,1
FULL DOOR



X-929
60 x 68,6
FULL DOOR

GLASS DOORS



X-930
60 x 206,6
GLASS DOOR



X-931
60 x 172,1
GLASS DOOR



X-932
60 x 137,6
GLASS DOOR



X-933
60 x 103,1
GLASS DOOR



X-934
60 x 68,6
GLASS DOOR

GLASS DOORS
IN ALUMINIUM FRAME



X-935
60 x 206,6
GLASS D.+AL FRAME



X-936
60 x 172,1
GLASS D.+AL FRAME



X-937
60 x 137,6
GLASS D.+AL FRAME



X-938
60 x 103,1
GLASS D.+AL FRAME



X-939
60 x 68,6
GL.D.+AL FRAME

SLAT
DOORS

SLAT DOORS
WE PRODUCE SLAT DOORS ONLY IN THESE THREE HEIGHTS. THEY CAN BE USED WITH THE CABINETS OF THE SAME HEIGHT ONLY. THEREFORE, THEY CAN'T BE COMBINED WITH OTHER COMPONENTS.



X-940
58 x 138
SLAT DOOR



X-941
58 x 103
SLAT DOOR



X-942
58 x 70
SLAT DOOR

DRAWERS AND
FILLING CABINETS

DRAWING AND FILLING CABINET MODULES CAN BE USED IN THE FOUR LOWER SHELVES IN THE CABINET. HIGHER POSITIONS ARE POORLY ACCESSIBLE. THESE ARE INDEPENDENT DRAWING SYSTEMS METABOX WHICH NEED TO BE FORGED INTO CABINETS.

THE FILLING CABINET MODULE (1) IN ONE DRAWER INTO ONE SHELF



X-943
59,6 x 34,5
FILLING CABINET

SINGLE-DRAWING MODULE INTO ONE SHELF



X-944
59,6 x 34,5
SINGLE-DRAWER

TWO-DRAWING MODULE INTO ONE SHELF



X-945
59,6 x 34,5
TWO-DRAWER

FIVE-DRAWING MODULE INTO TWO SHELVES



X-946
59,6 x 68,5
FIVE-DRAWER

DIVIDING
SHELF INSERTS

DIVIDING SHELF INSERTS CAN NEVER BE INSERTED INTO THE VERY BOTTOM OR THE VERY TOP SHELF OF THE CABINET. THICKENING INSERTS ARE USED TO CREATE SHELF FILLING CABINET. DIMENSIONS CORRESPOND TO A4 SIZE PAPERS.



































X-976
56,4 x 35,8 x 32,7
DIVIDING SHELF



X-977
56,4 x 35,8 x 32,7
DIVIDING SHELF

COMPONENTS
FOR VARIANT FURNITURE SETS
AT CASE WIDTH 400 MM

CASES	 <p>X-140 40 x 40 x 213 51 N</p>	 <p>X-200 40 x 40 x 178,5 52 N</p>	 <p>X-260 40 x 40 x 144 53 N</p>	 <p>X-310 40 x 40 x 109,5 54 N</p>	 <p>X-360 40 x 40 x 75 55 N</p>				
FULL DOORS	 <p>X-950 40 x 206,6 FULL DOOR</p>	 <p>X-951 40 x 172,1 FULL DOOR</p>	 <p>X-952 40 x 137,6 FULL DOOR</p>	 <p>X-953 40 x 103,1 FULL DOOR</p>	 <p>X-954 40 x 68,6 FULL DOOR</p>				
GLASS DOORS	 <p>X-955 40 x 206,6 GLASS DOOR</p>	 <p>X-956 40 x 172,1 GLASS DOOR</p>	 <p>X-957 40 x 137,6 GLASS DOOR</p>	 <p>X-958 40 x 103,1 GLASS DOOR</p>	 <p>X-959 40 x 68,6 GLASS DOOR</p>				
GLASS DOORS IN ALUMINIUM FRAME	 <p>X-960 40 x 206,6 GLASS D.+AL FRAME</p>	 <p>X-961 40 x 172,1 GLASS D.+AL FRAME</p>	 <p>X-962 40 x 137,6 GLASS D.+AL FRAME</p>	 <p>X-963 40 x 103,1 GLASS D.+AL FRAME</p>	 <p>X-964 40 x 68,6 GL.D.+AL FRAME</p>				
SLAT DOORS	<p>SLAT DOORS</p> <p>WE DON'T PRODUCE SLAT DOORS FOR CASE WIDTH 400 MM. THERE'S NO ENOUGH STORAGE SPACE IN THE WARDROBE.</p>								
DRAWERS AND FILLING CABINETS	<p>DRAWING AND FILLING CABINET MODULES CAN BE USED IN THE FOUR LOWER SHELVES IN THE CABINET. HIGHER POSITIONS ARE POORLY ACCESSIBLE. THESE ARE INDEPENDENT DRAWING SYSTEMS METABOX WHICH NEED TO BE FORGED INTO CABINETS.</p> <table border="0"> <tr> <td> <p>FILLING CABINET MODULE (1) IN ONE DRAWER INTO ONE SHELF</p>  <p>X-965 39,6 x 34,5 FILLING CABINET</p> </td> <td> <p>SINGLE-DRAWING MODULE INTO ONE SHELF</p>  <p>X-966 39,6 x 34,5 SINGLE-DRAWER</p> </td> <td> <p>TWO-DRAWING MODULE INTO ONE SHELF</p>  <p>X-967 39,6 x 34,5 TWO-DRAWER</p> </td> <td> <p>FIVE-DRAWING MODULE INTO TWO SHELVES</p>  <p>X-968 39,6 x 68,5 FIVE-DRAWER</p> </td> </tr> </table>					<p>FILLING CABINET MODULE (1) IN ONE DRAWER INTO ONE SHELF</p>  <p>X-965 39,6 x 34,5 FILLING CABINET</p>	<p>SINGLE-DRAWING MODULE INTO ONE SHELF</p>  <p>X-966 39,6 x 34,5 SINGLE-DRAWER</p>	<p>TWO-DRAWING MODULE INTO ONE SHELF</p>  <p>X-967 39,6 x 34,5 TWO-DRAWER</p>	<p>FIVE-DRAWING MODULE INTO TWO SHELVES</p>  <p>X-968 39,6 x 68,5 FIVE-DRAWER</p>
<p>FILLING CABINET MODULE (1) IN ONE DRAWER INTO ONE SHELF</p>  <p>X-965 39,6 x 34,5 FILLING CABINET</p>	<p>SINGLE-DRAWING MODULE INTO ONE SHELF</p>  <p>X-966 39,6 x 34,5 SINGLE-DRAWER</p>	<p>TWO-DRAWING MODULE INTO ONE SHELF</p>  <p>X-967 39,6 x 34,5 TWO-DRAWER</p>	<p>FIVE-DRAWING MODULE INTO TWO SHELVES</p>  <p>X-968 39,6 x 68,5 FIVE-DRAWER</p>						
DIVIDING SHELF INSERTS	<p>DIVIDING SHELF INSERTS</p> <p>THE SHELVES IN CASE WIDTH 400 MM CAN BE THICKENED BY ADDING NORMAL SHELVES.</p>								



(1)
x-101
x-100 + x-913 + x-904
x-140 + x-952 + x-967 + x-967
x-100 + x-903 + x-919 + x-919
x-120

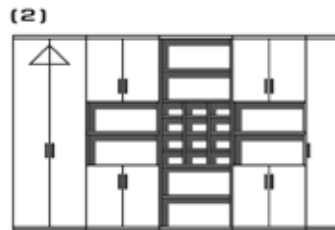

(2)
x-106
x-102
x-100 + x-975 + x-975
x-102
x-141

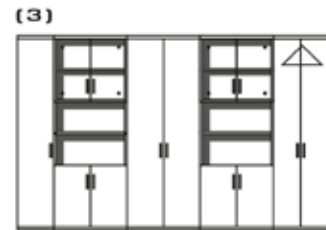

(3)
x-141
x-103
x-101
x-103
x-120

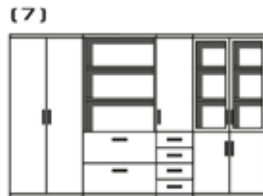

(7)
x-166
x-160 + x-919 + x-919
x-200 + x-953 + x-967 + x-967
x-160 + x-913 + x-904

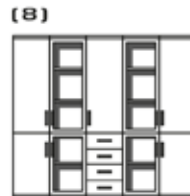

(8)
x-200 + x-953 + x-954
x-200 + x-963 + x-964
x-200 + x-953 + x-967 + x-967
x-200 + x-963 + x-964
x-200 + x-953 + x-954



(9)
x-320
x-311
x-281
x-200
x-161
x-210



(13)
x-221
x-220
x-225
x-240



(14)
x-240
x-220 + x-974 + x-919 + x-919
x-260 + x-954 + x-967 + x-967
x-220 + x-914 + x-904

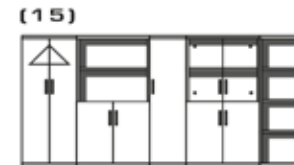

(15)
x-240
x-222
x-261
x-224
x-270

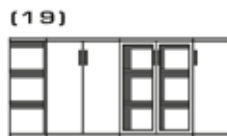

(19)
x-320
x-281
x-284
x-311



(20)
x-284
x-311
x-284



(21)
x-286
x-310
x-284
x-310
x-286



(25)
x-335
x-361
x-333
x-361
x-335



(26)
x-331
x-360
x-334
x-360
x-360 + x-967 + x-967



(27)
x-370
x-331
x-333
x-331
x-370

(4)



x-141
x-200 + x-961
x-261
x-284
x-261
x-200 + x-961
x-141

(5)



x-120
x-100 + x-974 + x-974
x-101
x-100 + x-910
x-141

(6)

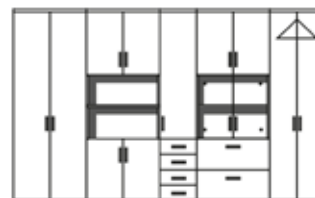

x-101
x-102
x-140 + x-952 + x-967 + x-967
x-100 + x-904 + x-909
+ x-919 + x-919
x-120

(10)



x-331
x-310 + x-963
x-160 + x-903 + x-919 + x-919
x-310 + x-963
x-331

(11)



x-310 + x-963
x-200 + x-951
x-334 + 1-840 (80cm)
x-200 + x-951
x-310 + x-963

(12)

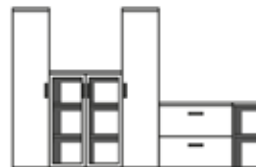

x-200 + x-951
x-284
x-200 + x-951
x-334
x-370

(16)



x-221
x-241 + x-976 + x-977
x-261
x-260
x-240
x-270

(17)



x-261
x-310 + x-963
x-335
x-310 + x-963
x-240

(18)



x-240
x-286
x-225
x-286
x-261

(22)

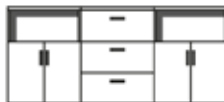

x-282
x-285
x-282

(23)



x-284
x-311
x-284

(24)



x-320
x-281
x-333
x-331
x-362
x-370

(28)

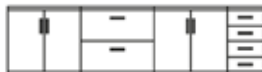

x-331
x-334
x-331
x-360 + x-967 + x-967

(29)



x-333
x-360 + x-967 + x-967
x-333

(30)



x-334
x-331
x-334

THE TABLE SYSTEM OFFERS A WIDE RANGE OF WORK, CONFERENCE, ADDITIONAL, CONNECTING AND COFFEE TABLE TOPS. IT ALLOWS TO FURNISH ALL TYPES OF OFFICE WORKPLACES AS WELL AS MEETING AND CONFERENCE ROOMS. YOU CAN CREATE GROUP WORKPLACES BY A SUITABLE CHOICE OF TABLE TYPES IN OPEN-SPACE OFFICES.

THE ERGONOMICALLY SHAPED CORNER TABLES ALLOW MAXIMAL UTILIZATION OF THE WORKSPACE AND OPTIMAL POSITIONING OF A MONITOR SCREEN WHILST WORKING ON PC. THERE'S ENOUGH SPACE FOR POSITIONING OF PC RACKS AND DRAWING CONTAINERS UNDER THESE TABLES. YOU CAN BE SITTING NEAR THE TABLE AND THE ARMS STAYS ON THE TABLE.

THE TABLES MAY BE SUPPLIED WITH CASTOR AND/OR FIXED CONTAINERS, PC RACKS, MONITOR COVERS, DRAW-OUT KEYBOARD RESTS, TABLE EXTENDERS, SCREENS, HANGING SHELVES AND WITH GROMMETS. YOU CAN CREATE PARTIAL PRIVACY AT WORK, WHICH BY NO MEANS LIMITS A TEAMWORK, BY USING DIVIDING SCREENS.

TABLE TOPS ARE MADE OUT OF HIGH QUALITY LAMINATED PARTICLE BOARDS 25 MM THICK. THEY ARE EDGED ALL-AROUND WITH AN ABS TAPE 2 MM THICK, WHICH IS IMPORTANT PROTECTING ELEMENT AGAINST MECHANICAL DAMAGE. THE METAL BASES ARE LINKED WITH HORIZONTAL TELESCOPIC TRUNK CUSTOMIZED FOR PLACING OF A SOCKETS AND AN ELECTRIFICATION WIRING. VERTICAL TABLE LEGS ARE CONTINUOUS AND THEY ALLOW TO PULL A CABLES THROUGH. COVERING IS DONE LIKE DECORATIVE SCREEN. THE BASES ARE HEIGHT-ADJUSTABLE. THEY CAN BE LEFT OPEN, OR YOU CAN HANG FRONT VERTICAL COVERING LAMINATED BOARDS TO THE TABLES. BASIC TABLES' HEIGHT IS 750 MM. THE TABLES CAN BE SUPPLIED WITH HEIGHT-ADJUSTABLE BASES BY REQUEST. SPECIAL HARDWARE IS USED FOR INTERCONNECTION OF THE TABLE TOPS. TABLE BASES, CENTRAL LEGS AND NORMAL LEGS ARE IN THE COLOUR OF ALUMINIUM OR ANTHRACITE.

THE TABLES ARE SHIPPED UNASSEMBLED.



T A B L E S Y S T E M

WORK TABLES AND TABLE TOPS

WORK TABLES
AND TABLE TOPS



1-600x
80 x 80
DP 80

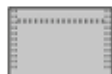

1-601x
120 x 80
DP 120



1-602x
140 x 80
DP 140

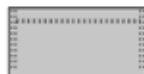

1-603x
160 x 80
DP 160

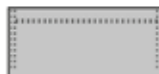

1-604x
180 x 80
DP 180



1-605x
160 x 100
DP 160 L



1-606x
160 x 100
DP 160 P



1-611x
160 x 120
DP 160 L

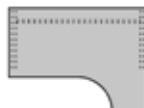

1-612x
160 x 120
DP 160 P



1-607x
180 x 100
DP 180 L



1-608x
180 x 100
DP 180 P



1-613x
180 x 120
DP 180 L



1-614x
180 x 120
DP 180 P



1-609x
200 x 100
DP 200 L



1-610x
200 x 100
DP 200 P

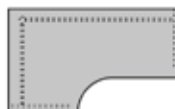

1-615x
200 x 120
DP 200 L



1-616x
200 x 120
DP 200 P



1-624x
160 x 100
DP 160 L

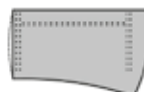

1-625x
160 x 100
DP 160 P

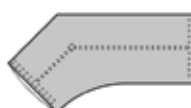

1-617x
216 x 113
DP 204 L

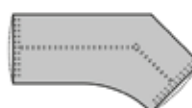

1-618x
216 x 113
DP 204 P

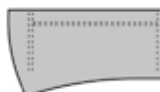

1-626x
180 x 100
DP 180 L

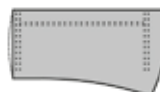

1-627x
180 x 100
DP 180 P

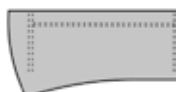

1-628x
200 x 100
DP 200 L

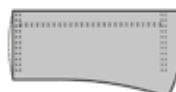

1-629x
200 x 100
DP 200 P

ADDITIONAL CODES TO THE ORDERING CODES OF THE WORK TABLE TOPS

1-600x - CODE BEFORE MODIFICATION

1-600 - SINGLE TABLE TOP ORDER

1-6001 - TABLE TOP ON METAL BASE

1-6002 - TABLE TOP ON METAL
HEIGHT-ADJUSTABLE BASE



1-620x
215 x 131
DP 215

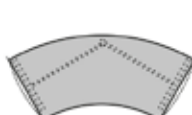

1-621x
215 x 98
DP 215

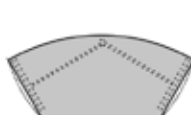

1-622x
215 x 98
DP 215

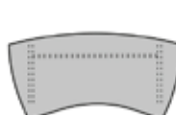

1-623x
200 x 100
DP 200

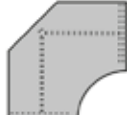

1-619x
136 x 136
DP 140

**CONFERENCE
TABLE TOPS**



1-640
80 x 80
SQUARE CTT



1-641
120 x 80
RECTANGLE CTT



1-642
140 x 80
RECTANGLE CTT



1-643
160 x 80
RECTANGLE CTT



1-644
180 x 80
RECTANGLE CTT



1-648
150 x 90
BARRELLED CTT



1-649
200 x 100
BARRELLED CTT



1-650
150 x 90
ELLIPSE CTT



1-651
215 x 100
ELLIPSE CTT



1-652
průměr 80
CIRCLE CTT



1-645
90 x 90
CONIC CTT



1-646
150 x 100
CONIC CTT



1-647
200 x 110
CONIC CTT



1-654
průměr 120
CIRCLE CT



1-653
průměr 100
CIRCLE CT

**COFFEE
TABLE TOPS**



1-670
průměr 65
CIRCLE CTT



1-671
110 x 65
ELLIPSE CTT



1-672
65 x 65
BARRELED CTT



1-673
110 x 65
BARRELED CTT

**CONNECTING
TABLE TOPS**



1-720
80 x -
DS 45



1-721
80 x -
DS 60



1-722
80 x 80
DS 90



1-723
80 x -
DS 120



1-724
80 x -
DS 135



1-726
150 x 80
DS L



1-727
150 x 80
DS P



1-725
120 x 120
DS



1-728
120 x 109
DS



1-729
136 x 136
DS



1-730
192 x 95
DS

**CENTRAL AND TABLE
LEGS**

NOTE:

CENTRAL AND TABLE LEGS ARE IN ANTHRACITE OR ALUMINIUM DESIGN BY DEFAULT (THE SAME PRICE AND ORDER CODE). PLEASE, SPECIFY THE SELECTED DESIGN IN THE ORDER. IF ORDERED, THE LEGS MAY BE DELIVERED EVEN IN CHROME OR WOOD DESIGN.



1-750
6/45 v.72
CL CONF. RAL



1-752
6/40 v.53
CL COFFEE RAL



1-754
6 v.72
TABLE LEG



1-756
6 v.53
TABLE LEG

ADDITIONAL TABLE TOPS, BASES FOR THE TABLES

ADDITIONAL
TABLE TOPS



1-680
80 x 61
RECTANGLE ATT

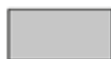

1-681
120 x 61
RECTANGLE ATT

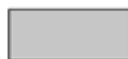

1-682
140 x 61
RECTANGLE ATT

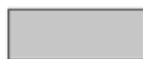

1-683
160 x 61
RECTANGLE ATT



1-684
průměr 80
ATT



1-701
120 x 80
ATT



1-702
140 x 80
ATT



1-703
160 x 80
ATT



1-704
180 x 80
ATT



1-685
diameter 100
ATT



1-689
80 x 40
ATT L



1-690
80 x 40
ATT P



1-691
120 x 57
ATT L



1-692
120 x 57
ATT P



1-686
diameter 100
ATT



1-693
100 x 80
ATT L



1-694
100 x 80
ATT P



1-695
100 x 100
ATT L



1-696
100 x 100
ATT P



1-687
120 x 120
ATT



1-697
120 x 45
ATT



1-698
140 x 45
ATT



1-699
160 x 45
ATT



1-700
180 x 45
ATT



1-688
průměr 120
ATT



1-705
157 x 122
ATT L



1-706
157 x 122
ATT P

METAL BASES
FOR THE TABLES

MARGINAL

MEDIAL



FIXED
BASE

80cm	1-760
120cm	1-761
140cm	1-762
160cm	1-763
180cm	1-764

NOTE:

THE METAL BASES CAN BE ORDERED IN THE MARGIN OR MEDIAL VERSION. PRICE IS THE SAME FOR BOTH VERSIONS. PLEASE, SPECIFY ORDERED VERSION OF THE BASE WHEN YOU ORDER SINGLE BASES.

WHEN YOU ORDER THE BASE TOGETHER WITH A TABLE TOP, WE DETERMINE THE APPROPRIATE TYPE OF THE BASE (IF YOU DON'T SPECIFY IT).

KRAJOVÁ

STŘEDO VÁ



HEIGHT-
ADJUSTABLE
BASE

80cm	1-766
120cm	1-767
140cm	1-768
160cm	1-769
180cm	1-770

ACCESSORIES FOR MERGING THE TABLES
AND FOR METAL BASES



1-859

EXTENSION TRUNK
(IT CAN BE USED FOR
SMALLER ADDITIONAL
TOPS INSTEAD OF
TABLE LEG)



1-858

FP
PLATE FOR FITTING
OF THE TABLE TOPS

EXTENSIONS FOR
WORK TABLES



1-800
80 x 24 x 25
N80

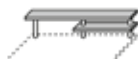

1-801
120 x 24 x 25
N120

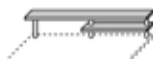

1-802
140 x 24 x 25
N140



1-803
160 x 24 x 25
N160

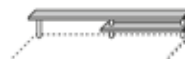

1-804
180 x 24 x 25
N180

SCREENS AND HANGING SHELVES
FOR THE WORK TABLES



1-805
80 x 40
P80



1-806
120 x 40
P120



1-807
140 x 40
P140



1-808
160 x 40
P160



1-809
180 x 40
P180



1-810
80 x 44
PZ80

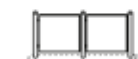

1-811
120 x 44
PZ120



1-812
140 x 44
PZ140



1-813
160 x 44
PZ160



1-814
180 x 44
PZ180



1-820
65 x 21 x 30
PP95



1-821
50 x 21 x 30
PP50



1-822
60 x 21 x 30
PP60



1-823
70 x 21 x 30
PP70



1-824
80 x 21 x 30
PP80

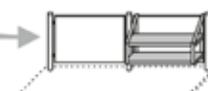

SCREENS FOR THE
WORK TABLES CAN
BE CUSTOM-MADE
AS **DOUBLE-SIDED**.
FOR THE CENTRE
BETWEEN TWO
TABLES. PLEASE,
SPECIFY THIS FACT
IN THE ORDER NOTE.

ADDITIONAL BACKS
FOR THE TABLES



1-830
80 x 45
ZS80



1-831
120 x 45
ZS120



1-832
140 x 45
ZS140



1-833
160 x 45
ZS160

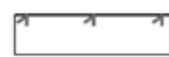

1-834
180 x 45
ZS180

MONITOR
COVERS



1-853
40 x 25
MC STRAIGHT



1-854
60+60 x 25
KM 90



1-855
40+40 x 25
KM 120



1-856
40+40 x 25
KM 135

ACCESSORIES



1-850

DRAW-OUT
KEYBOARD REST



1-851

PC RACK



1-860

PC RACK



1-861

PC RACK



1-862

PC CART



1-863

PEN RACK



1-857

GROMMET

SAMPLE SETS
OF THE TABLES' COMBINATION

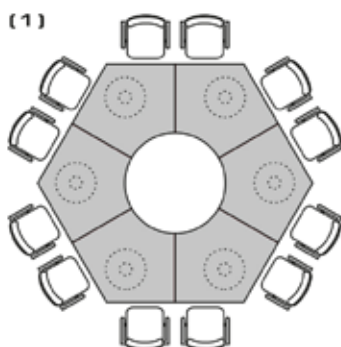

(1)
6x - 1-728
+ 6x central leg

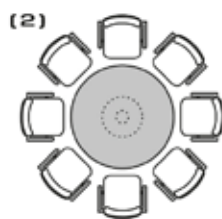

(2)
1x - 1-654
+ 1x central leg

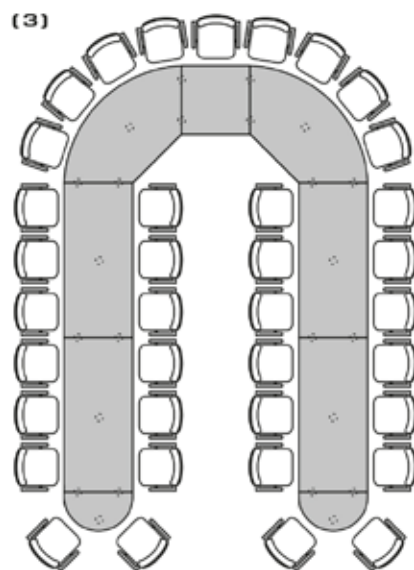

(3)
1x - 1-640
2x - 1-730
4x - 1-644
2x - 1-684
+ 24x table leg

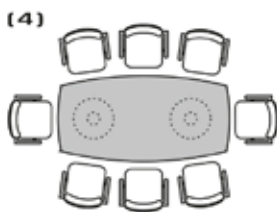

(4)
1x - 1-649
+ 2x central leg

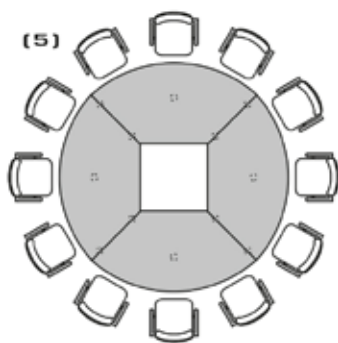

(5)
4x - 1-730
+ 12x table leg

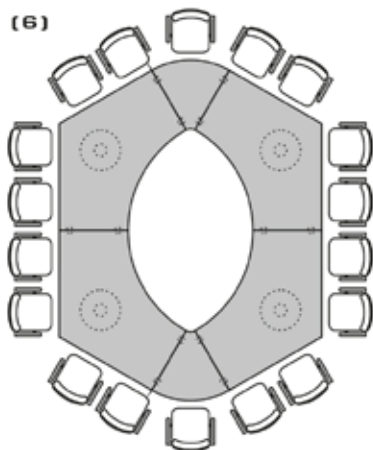

(6)
4x - 1-620
2x - 1-721
+ 4x central leg
+ 12x table leg

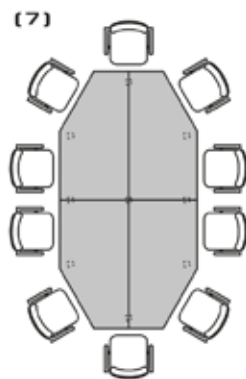

(7)
2x - 1-726
2x - 1-727
+ 9x table leg

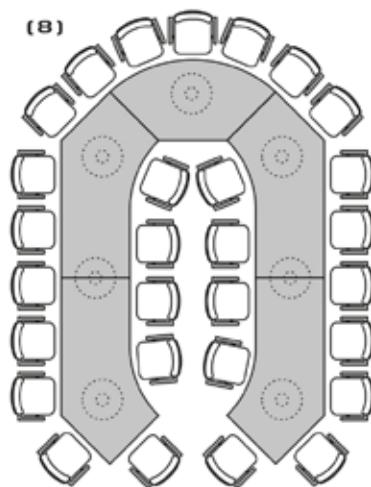

(8)
1x - 1-730
2x - 1-617
2x - 1-618
+ 7x central leg

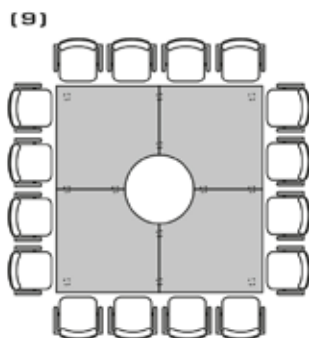

(9)
4x - 1-725
+ 12x table leg

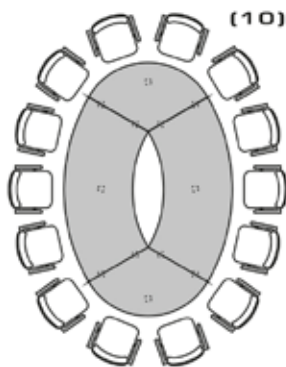

(10)
2x - 1-621
2x - 1-723
+ 12x table leg

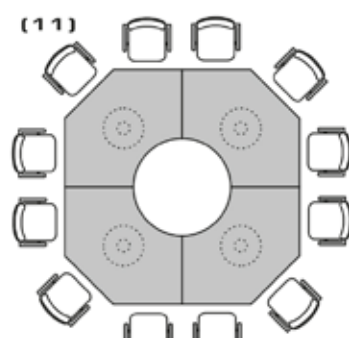

(11)
4x - 1-619
+ 4x central leg

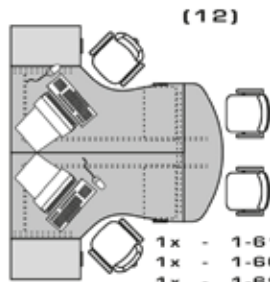

- (12)
1x - 1-610x
1x - 1-609x
1x - 1-699
+ 2x table cabinet
+ 2x container
+ 1x table leg
+ 2x extending trunk

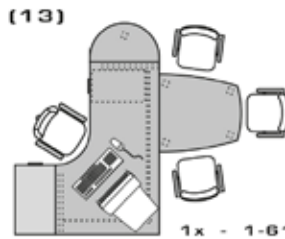

- (13)
1x - 1-616x
1x - 1-684
1x - 1-645
+ 1x container
+ 1x slat-door cabinet
+ 5x table leg

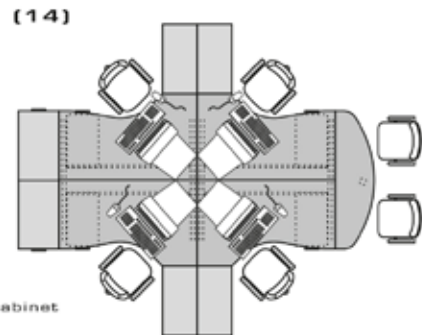

- (14)
2x - 1-605x
2x - 1-606x
1x - 1-699
+ 2x table cabinet
+ 4x container
+ 1x table leg
+ 4x slat-door cabinet (X-335)

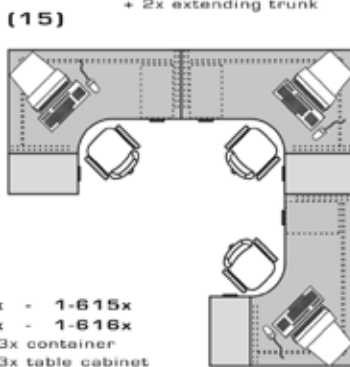

- (15)
1x - 1-615x
2x - 1-616x
+ 3x container
+ 3x table cabinet

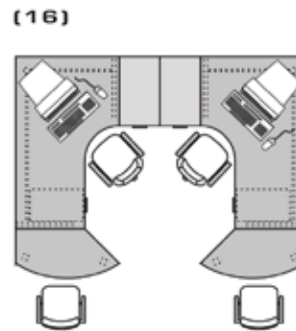

- (16)
1x - 1-615x
1x - 1-616x
2x - 1-691
+ 4x table leg
+ 2x table cabinet
+ 2x container

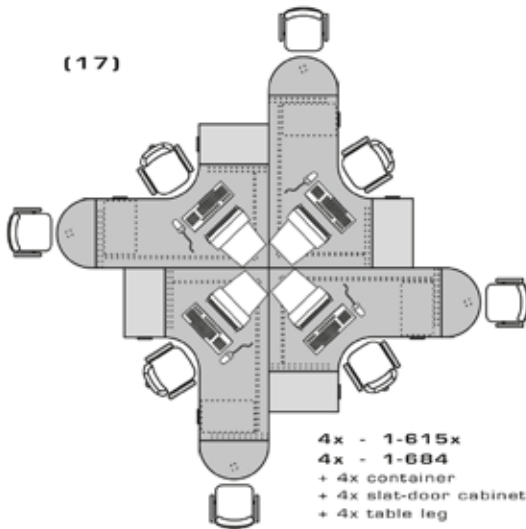

- (17)
4x - 1-615x
4x - 1-684
+ 4x container
+ 4x slat-door cabinet
+ 4x table leg

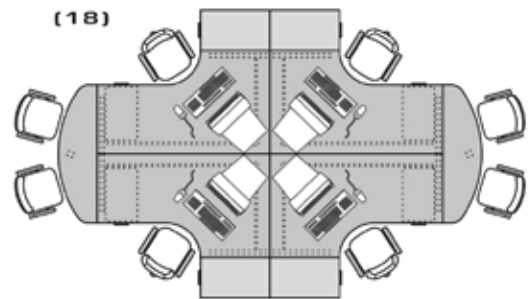

- (18)
2x - 1-615x
2x - 1-616x
2x - 1-699
+ 4x container
+ 4x slat-door cabinet
+ 2x table leg

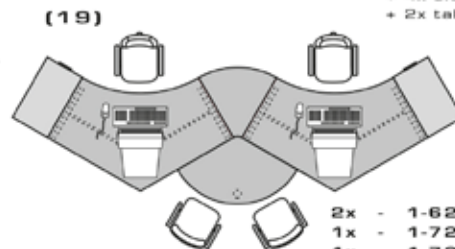

- (19)
2x - 1-620x
1x - 1-721
1x - 1-723
+ 1x table leg
+ 2x solid container

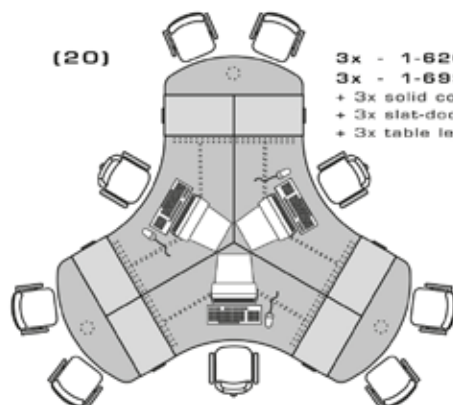

- (20)
3x - 1-620x
3x - 1-699x
+ 3x solid container
+ 3x slat-door cabinet
+ 3x table leg

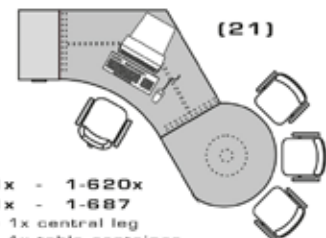

- (21)
1x - 1-620x
1x - 1-687
+ 1x central leg
+ 1x table container

SAMPLE SETS
OF THE TABLES' COMBINATION

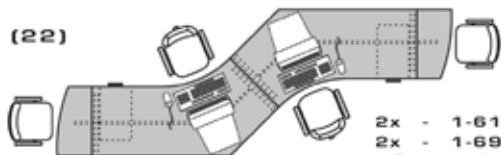

(22)

- 2x - 1-617x
- 2x - 1-690
- + 2x extending trunk
- + 2x container

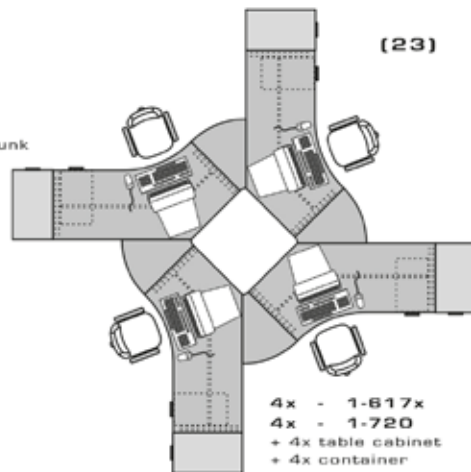

(23)

- 4x - 1-617x
- 4x - 1-720
- + 4x table cabinet
- + 4x container

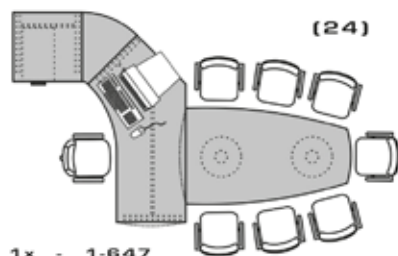

(24)

- 1x - 1-647
- 1x - 1-617x
- 1x - 1-720
- 1x - 1-600x
- + 2x central leg
- + 1x container

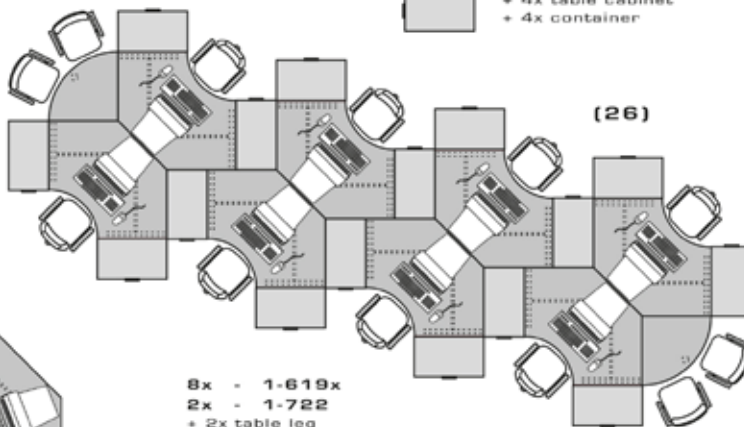

(26)

- 8x - 1-619x
- 2x - 1-722
- + 2x table leg
- + 8x table container
- + 8x cabinet filling register w. 80 h. 75 (x-334)

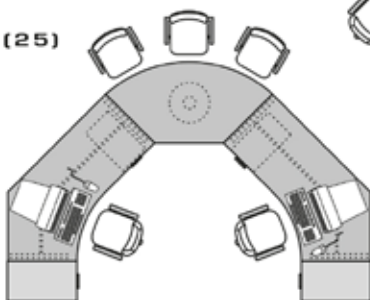

(25)

- 1x - 1-730
- 1x - 1-617x
- 1x - 1-618x
- + 1x central leg
- + 2x container
- + 2x table cabinet

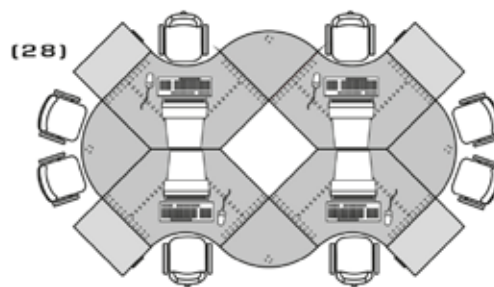

(28)

- 4x - 1-619x
- 4x - 1-722
- + 4x table leg
- + 4x table container

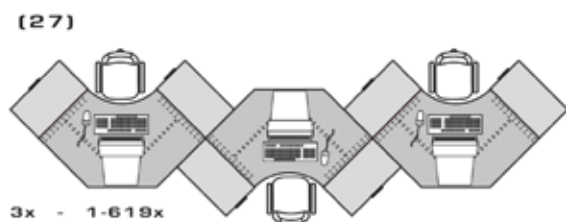

(27)

- 3x - 1-619x
- + 3x table container
- + 3x cabinet filling register w. 80 h. 75 (x-334)

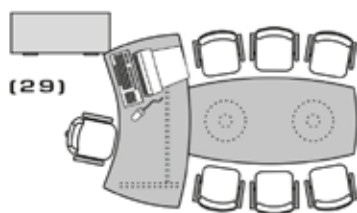

(29)

- 1x - 1-649
- 1x - 1-623x
- + 2x central leg
- + 1x big container

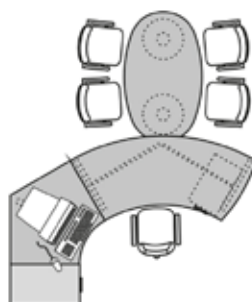

(30)

- 1x - 1-621x
- 1x - 1-650
- 1x - 1-728
- + 2x central leg
- + 1x table leg
- + 1x table cabinet
- + 1x container

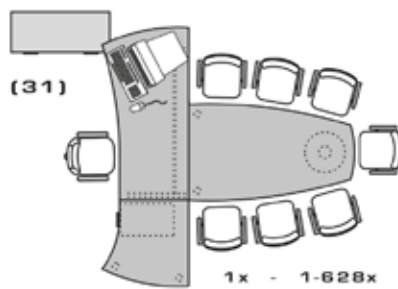

(31)

- 1x - 1-628x
- 1x - 1-647
- 1x - 1-696
- + 1x central leg
- + 4x table leg
- + 1x big container
- + 1x container



profil[®]
NÁBYTEK

PROFIL NÁBYTEK, A.S.
HRADSKÁ 280, 396 01 HUMPOLEC
CZECH REPUBLIC
TEL. 00420 565 300 111
FAX 00420 565 300 112
E-MAIL: INFO@PROFIL-NABYTEK.CZ
WWW.PROFIL-NABYTEK.CZ

